

VARIABLE AIR VOLUME CIRCULAR DAMPER

e-VAV self-sufficient & connected

The **e-VAV** is a variable air volume damper which enables:

- to manage the airflow of fresh air in offices, commercial buildings and classrooms.
- to regulate the airflow and measure the indoor air quality with its integrated sensors (humidity, temperature and CO₂).

The airflow can also be regulated by an external 0-10 V signal or a dry contact from a remote sensor (presence or CO₂ sensor).

e-VAV is energy self-sufficient and doesn't require any power wiring. It generates its own electricity thanks to its turbine operating by the air flow and its energy harvesting system. This energy is used to supply electricity to the damper and measure indoor air quality.



VERSIONS

- **e-VAV**, variable air volume damper, energy self-sufficient
- **e-VAV QAI**, variable air volume damper with air quality sensor (CO₂), energy self-sufficient
- **e-SENSE**, air quality sensor (CO₂, HR, T°), energy self-sufficient
- **Pack e-VAV QAI** : made of one **e-VAV QAI** with CO₂ sensor for extract, one **e-VAV** for supply, and one specific master/slave wire

CONSTRUCTION

	e-VAV			
	Ø125 mm	Ø160 mm	Ø200 mm	Ø250 mm
Casing	PC-ABS, certified M1		PC-ABS <i>MO in option</i>	
Iris damper	PC-ABS, certified M1			
Airproofing membrane	Seal			
Connection	Male connection with EPDM seal			

TECHNICAL SPECIFICATIONS

	e-VAV
Casing airtightness	Class C
Upstream/downstream airtightness	Not classified
Operating temperature	+0°C to +45°C
Operating relative humidity	0...80 % RH (non-condensing)
Wire control (room sensors)	0..10 V signal or ON/OFF switch
Communication	LoRaWan

VARIABLE AIR VOLUME CIRCULAR DAMPER

e-VAV self-sufficient & connected

DIMENSIONS

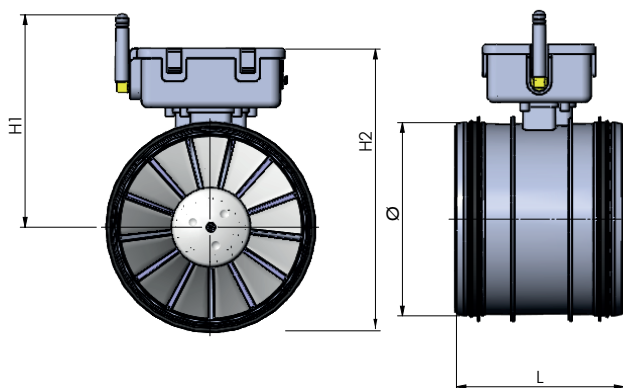

	Ø125 mm	Ø160 mm	Ø200 mm	Ø250 mm
Length in mm	105	105	200	200
Height H1 in mm	130	156	173	198
Height H2 in mm	172	190	248	298
Weight in kg	0.45	0.70	2	4

AIR MANAGEMENT SPECIFICATION

	e-VAV			
	Ø125 mm	Ø160 mm	Ø200 mm	Ø250 mm
Airflow range min	30 m³/h	40 m³/h	60 m³/h	90 m³/h
Airflow range max	220 m³/h	400 m³/h	600 m³/h	1100 m³/h
Pressure range min - max	10 Pa - 250 Pa			

The advised airflow range is from 0.5 m/s to 5 m/s

ACOUSTIC PERFORMANCES WITH A 50 Pa PRESSURE LOSS

	Air velocity m/s	Airflow m³/h	63 Hz	125 Hz	250 Hz	500 Hz	1000 Hz	2000 Hz	4000 Hz	8000 Hz	Global Lw (dBA)
			Air-regenerated, sound power level Lw								
Ø125 mm	0.5	22	53	47	44	37	27	19	19	21	39
	1	44	55	64	54	39	37	23	20	21	50
	2	88	53	56	51	43	42	32	26	21	47
	3	133	54	52	56	47	45	37	32	22	50
	4	177	55	54	57	51	49	45	37	24	54
Ø160 mm	0.5	36	55	40	34	26	21	16	17	31	33
	1	72	64	55	47	41	37	34	31	32	38
	2	144	62	57	57	50	41	37	33	33	46
	3	217	57	55	59	42	38	31	24	32	49
	4	289	58	57	54	46	42	36	30	30	49
	5	361	57	57	62	49	45	46	35	32	56

Data for Ø200 and Ø250 on request

VARIABLE AIR VOLUME CIRCULAR DAMPER

e·VAV self-sufficient & connected

TECHNICAL SPECIFICATIONS SENSORS AND COMMUNICATION

Relative Humidity and Temperature sensor	RH operating range	0 to 80 % (non-condensing)
	Accuracy	± 3 %
	Operating temperature T°	0 to 45 °C
	Accuracy	± 1°C
	Type	Low power MEMS sensor
CO ₂ sensor	CO ₂ operating range	0 to 2000 ppm
	Accuracy	± 50 ppm
	Type	NDIR low power
Communication RF	Protocol	LoRaWan
	Frequency band	868 GHz

DESCRIPTION

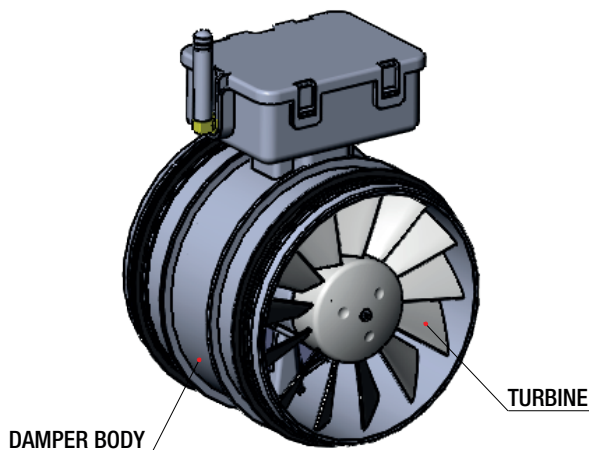

The external box has 1 plug:

- One RJ12 to connect a CO₂ sensor or a presence detector

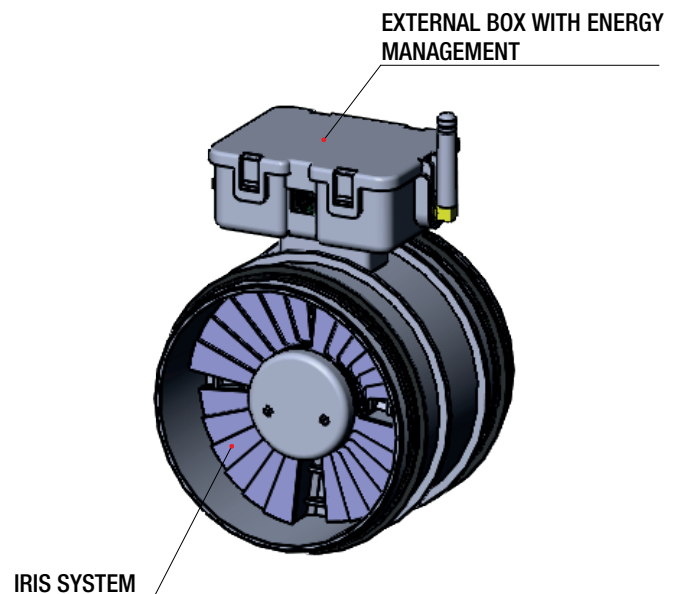

VARIABLE AIR VOLUME CIRCULAR DAMPER

e-VAV self-sufficient & connected

OPERATING PRINCIPLE

Supply or exhaust air controlled by a room CO₂ sensor with an e-VAV-S (S=Standard)

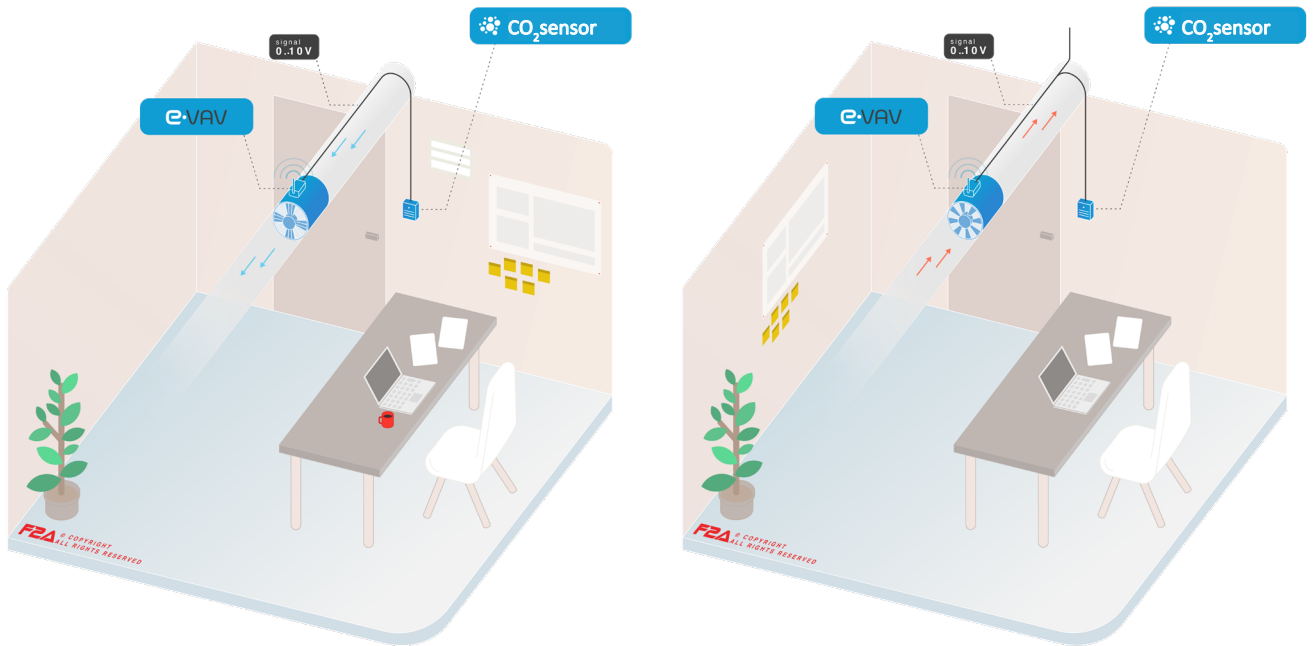

The damper is controlled by a 0..10V signal from a room CO₂ sensor which itself measures in real time the CO₂ concentration and sends a 0..10 V signal to the damper to adapt the airflow rate.

The damper is factory set. The remote sensor can be supplied with 24 V by an external source.

The CO₂ sensor can be replaced by a presence detector.

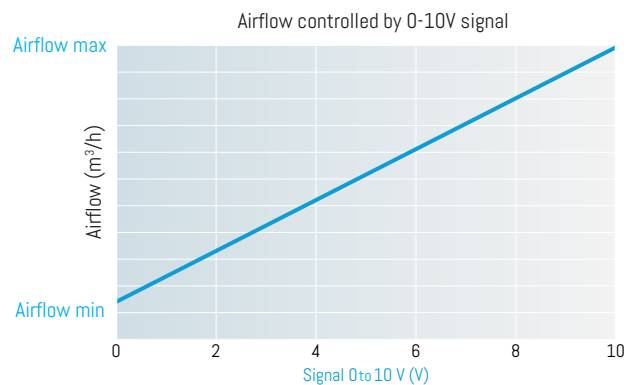
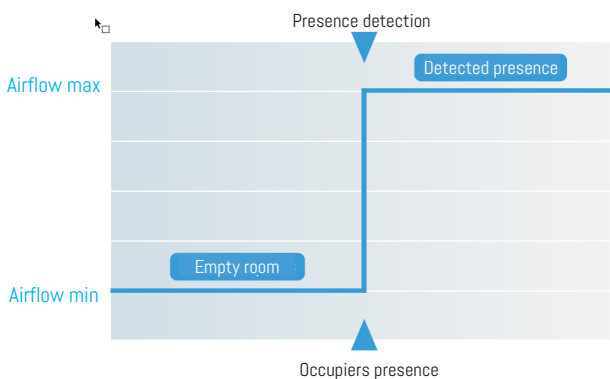

VARIABLE AIR VOLUME CIRCULAR DAMPER

e-VAV self-sufficient & connected

Wiring diagram

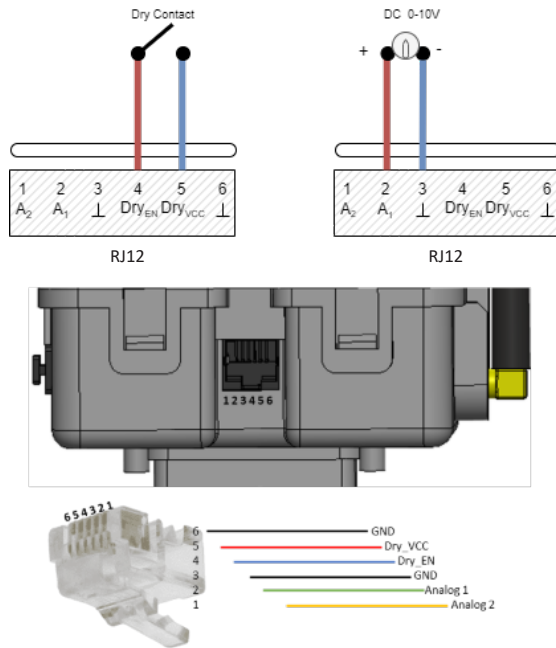

Equipment list:

- 1 e-VAV
- 1 CO₂ room sensor 24 V
- 1 power transformer 230 V-24 V
- In option: presence detector.

Exhaust air controlled by an e-VAV QAI with integrated CO₂ sensor



The **e-VAV QAI** damper in the exhaust is controlled by the CO₂ measured by its integrated sensor. The damper is factory set with minimum and maximum airflow and CO₂ values.

No connection needed

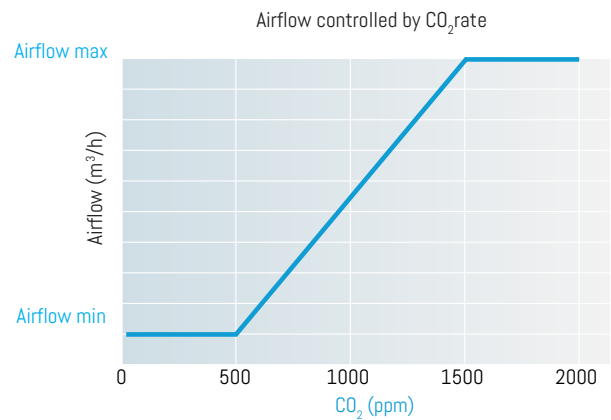

Equipment list:

- 1 e-VAV QAI

CO₂ min: 500 ppm → **airflow min**
 CO₂ max: 1500 ppm → **airflow max**

VARIABLE AIR VOLUME CIRCULAR DAMPER

e-VAV self-sufficient & connected

Exhaust air controlled by an e-VAV QAI with integrated CO₂ sensor at the exhaust and one slave e-VAV at the supply

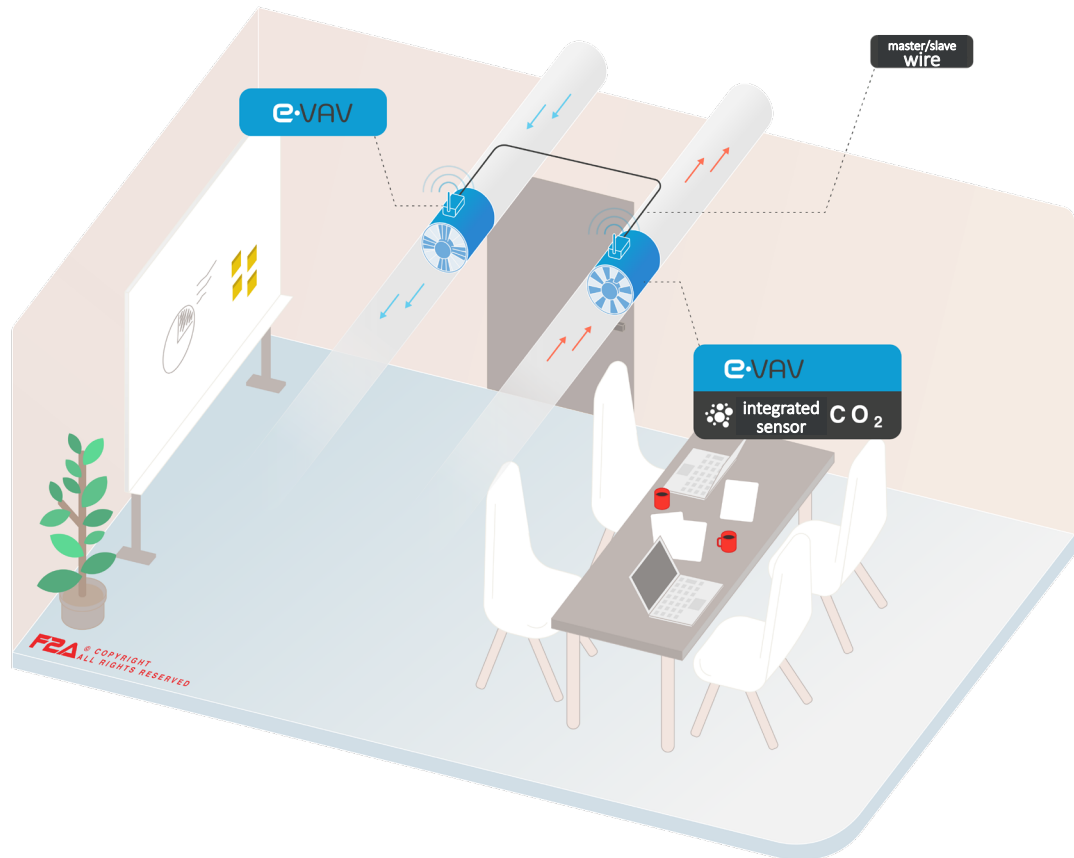

The e-VAV QAI damper in the exhaust is controlled by the CO₂ measured from its integrated sensor. It is factory set with minimum and maximum airflow and CO₂ values.

The e-VAV damper at the supply is on slave mode controlled by the e-VAV QAI master. The signal is transmitted via a specific wire provided.

Pack e-VAV QAI equipment list:

- 1 e-VAV QAI at the exhaust
- 1 e-VAV at the supply
- 1 master/slave wire

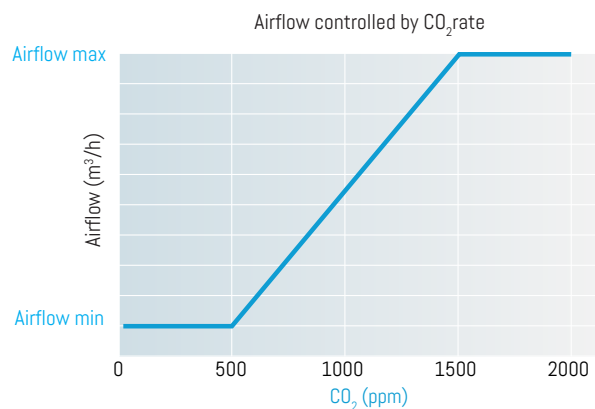

VARIABLE AIR VOLUME CIRCULAR DAMPER

e-VAV self-sufficient & connected

Wiring diagram



1/ Select the RJ45 connection
On the lateral side of the electrical box



2/ Plug the cable delivered with the e-VAV



3/ Check the cable is well connected then do
the same with the other e-VAV



4/ The 2 e-VAV are now connected
in master/slave mode

INSTALLATION

Always install the **e-VAV** with the airflow facing the turbine.

The damper fits between two sections of ductwork thanks to EPDM seals. No screw is needed.



COMMISSIONING

The **e-VAV** needs an air flow to be activated. Start the AHU and wait for the **e-VAV** to start the regulation. The start-up time is a maximum of 60 minutes and an average of 40 minutes.

After 60 min, the **e-VAV** starts to reach the target according to the signal it receives: dry contact, 0-10V or CO₂.

LoRa commissioning: all products are labelled with their LoRa identifier

N° Article :	EVAVD125-S	Designation :	EVAV D125 HRT		
Dev EUI :	XX-XX-XX-XX-XX-XX-XX-XX-XX				
Label :	eVAV T5	Building :	n°1	Place :	R5
Regulation :	0-10 V				
Airflow min :	40	Value min :	0 V		
Airflow max :	220	Value max :	10 V		

VARIABLE AIR VOLUME CIRCULAR DAMPER

e-VAV self-sufficient & connected

COMMISSIONING WITH REMOTE CONTROL

For more information, ask for the dedicated technical documentation of the e-VAV remote control. You will find all the information for modifying the airflow and the other parameters.



«Main» Menu

Turn on the remote control, plug the RJ45 and press “Connect e-VAV”

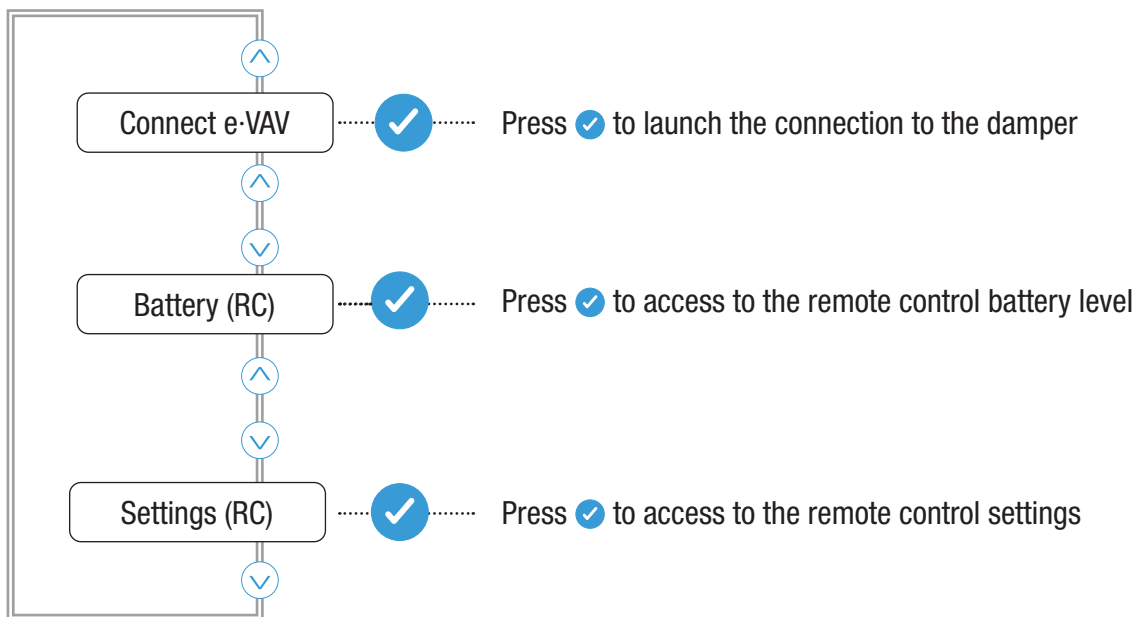

VARIABLE AIR VOLUME CIRCULAR DAMPER

e-VAV self-sufficient & connected

«Connect e-VAV» Menu

Select the appropriate menu according to your needs

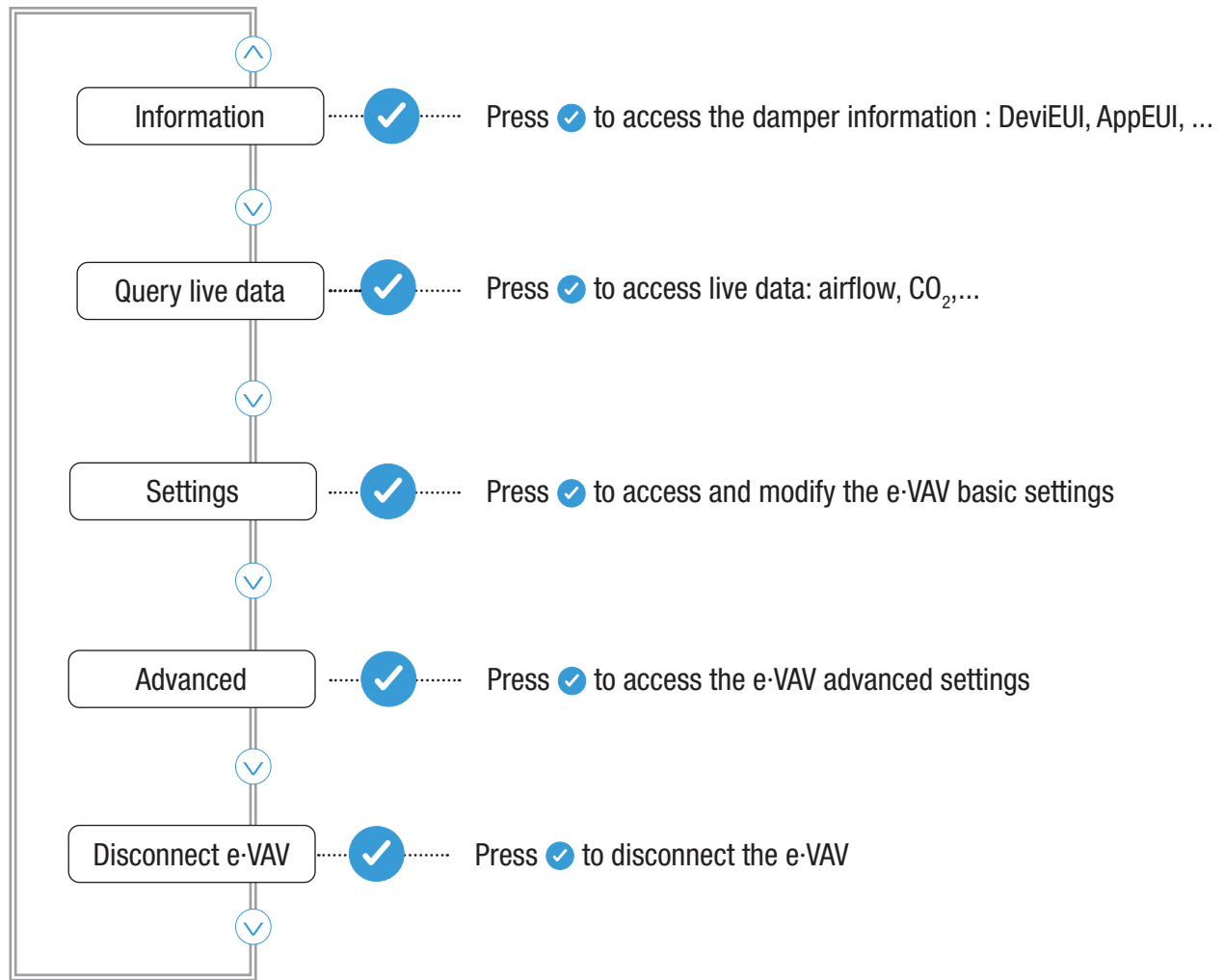

The remote control allows you to modify all the e-VAV parameters : airflow, CO₂ level,

In order to modify parameters, the remote control has to be wirely plug into e-vav.

VARIABLE AIR VOLUME CIRCULAR DAMPER

e-VAV self-sufficient & connected

MONITOR YOUR INDOOR AIR QUALITY AND ACT ON YOUR SYSTEM

The **e-VAV** communicates with LoRaWAN protocol. It allows you to manage all parameters remotely.

With the integrated sensors, you can monitor the indoor air quality (CO₂), the comfort and all the airflows in your buildings. You can check the damper efficiency, optimize the consumption and the costs.

You can act to change the configuration of the damper remotely controlled through the LoRa network.

It allows you to adjust your ventilation system to optimize it during all the building life cycle.



Benefits of the LoRa **e-VAV**:

- Monitor the indoor air quality during the whole lifetime of the building
- Act and control your variable air volume damper remotely
- Detect and solve issues without human intervention

Products list:

- **e-VAV**: self-sufficient variable air volume damper
- Gateways: box to receive and send LoRa information
- Dashboard: a ready-to-roll solution to monitor all the dampers



The **e-VAV** can also interact with other IoTs products in the building as for instance a room CO₂ sensor which has LoRa communication.

FT_e-VAV_05/2023_EN - Information and data can not be considered as contractual. Design and data changes may occur without notice during F2A's continuous product development.