

BALANCING DAMPER

RKO

The industrial dampers type RKO are designed to control HVAC ductworks. The RKO range is suitable for large-sized ventilation networks (up to 2 000 x 2 000 mm).

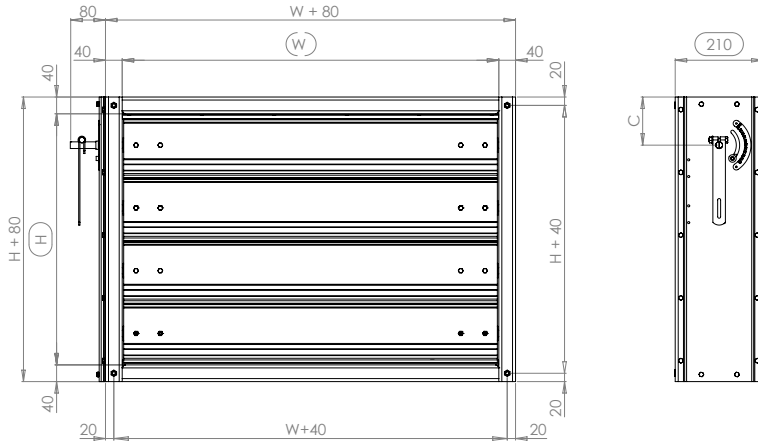

CHARACTERISTICS

		RKO
Upsteam/downstream airtightness according to EN 1751		Not classified
Frame airtightness according to EN 1751		Class A <i>Option</i> : Class C
Frame	Material	Galvanized steel <i>Option</i> : stainless steel AISI 304 L or 316 L
	Thickness	3 mm
	Depth	210 mm
	Flange	40 mm <i>Option</i> : flange according to ISO 15138
	Drilling	Ø10 in angles <i>Option</i> : drilling according to ISO 15138 - Special drilling on request
Blades	Material	Galvanized steel <i>Option</i> : stainless steel AISI 304 L or 316 L
	Thickness	2 x 1.5 mm
	Height	150 mm
	Bearings	Teflon bearings with zinc-plated steel cage <i>Options</i> : stainless steel cage, bronze bearings
	Shafts	Ø 15 mm zinc-plated steel <i>Options</i> : stainless steel AISI 304L - 1.4307 ou AISI 316L - 1.4404
Linkage		Opposed blade operation in zinc-plated steel <i>Option</i> : stainless steel AISI 304 L or 316 L
Control		Manual : smooth shaft Ø16 - lever and locking device Suitable for actuator : smooth shaft Ø16 - lenght 130 mm Special adaptation according to the actuator
Dimensions		Width W from 150 to 2 000 mm with a 50 mm pitch Height H from 150 to 2 000 mm with a 50 mm pitch Circular adaptation from Ø100 to Ø1250 mm

BALANCING DAMPER

RKO

WEIGHT (Kg)

H \ L	200	400	600	800	1000	1200	1400	1600	1800	2000
200	11	14	18	21	25	29	32	36	40	43
400	15	20	24	28	33	37	42	46	51	55
600	22	28	34	40	46	52	58	64	70	76
800	27	34	41	47	54	61	68	74	81	88
1000	32	39	47	54	62	70	77	85	92	100
1200	38	48	57	66	75	84	93	102	111	120
1400	43	53	63	73	83	93	103	113	122	132
1600	48	59	70	80	91	102	112	123	133	144
1800	55	67	79	92	104	116	128	140	153	165
2000	60	73	86	99	112	125	138	151	164	177

MOTOR TORQUE (Nm)

In order to determine the motor torque, consider the maximum accidental pressure. The design must include a safety coefficient.

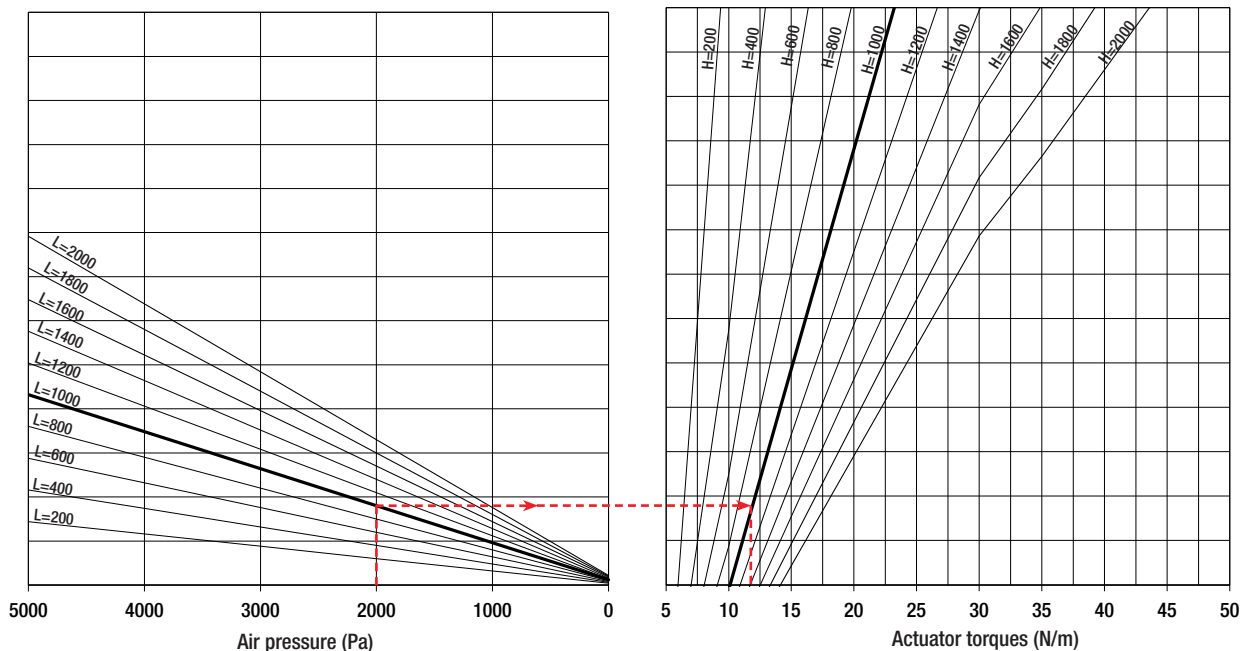

RKO damper

Ex :

$\Delta P = 1000 \text{ Pa}$

Damper :

L 2000 x H=1000

=>Cm = 12 Nm

BALANCING DAMPER

RK0

MECHANICAL RESISTANCE

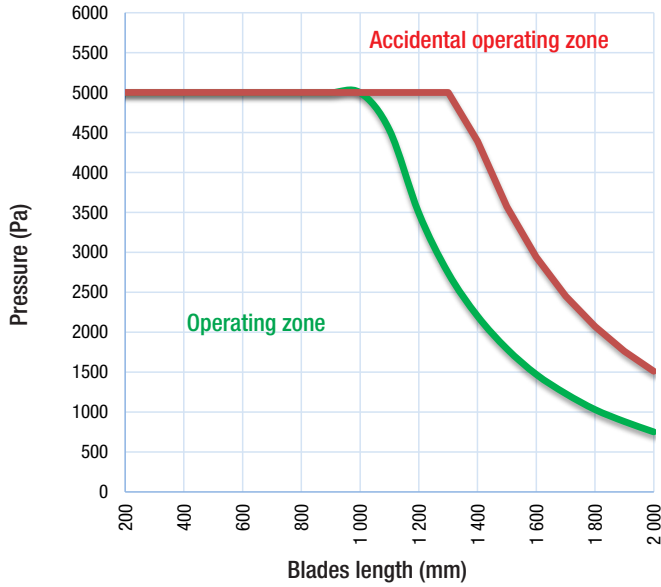

PRESSURE LOSS

Pressure loss (Pa) according to air velocity (m/s) and blades' opening angle (°). Damper ducted upstream and downstream.

0° = damper fully open

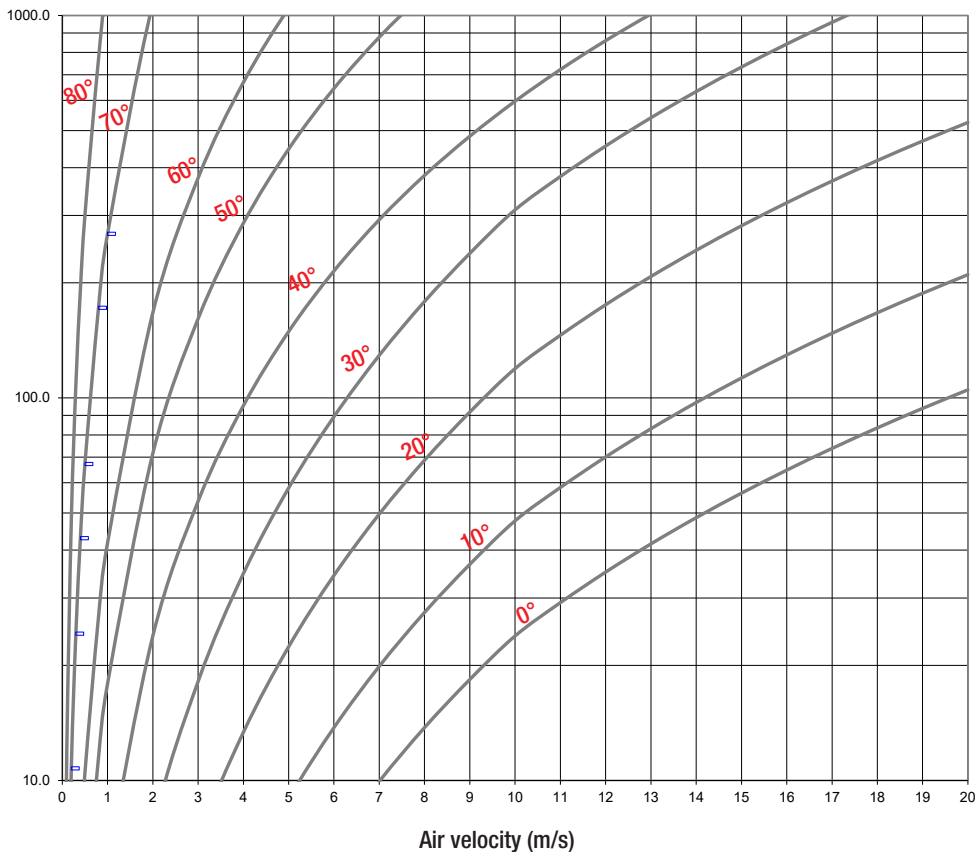

BALANCING DAMPER

RK0

ISO 15138 FLANGE AND DRILLING

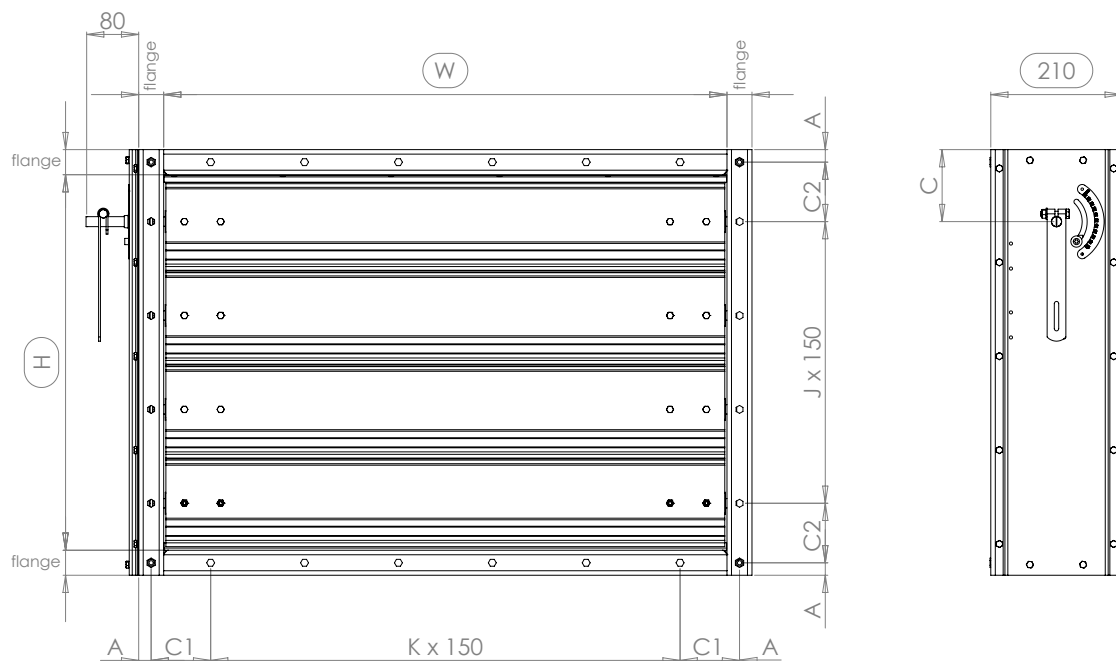

ISO 15138	Flange width	A	C1 / C2	Ø
W or H ≤ 350	40 mm	10 mm	75 < Cx ≤ 150	10
W or H > 350 ≤ 1000	50 mm	20 mm	75 < Cx ≤ 150	12
W or H > 1000	80 mm	40 mm	75 < Cx ≤ 150	14