

SHUT-OFF DAMPER

RKE-ATEX

The purpose of this specification is to present the main features of RKE-ATEX dampers. Those products are dedicated to installations in EXplosive ATmospheres zone 1. They are designed to prevent any risk of explosion in gaseous and dusty atmospheres.

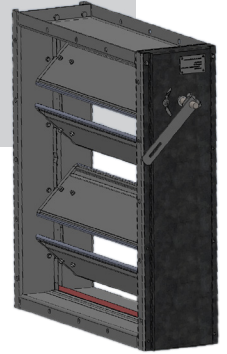

DESIGN (equipped with pneumatic actuator)

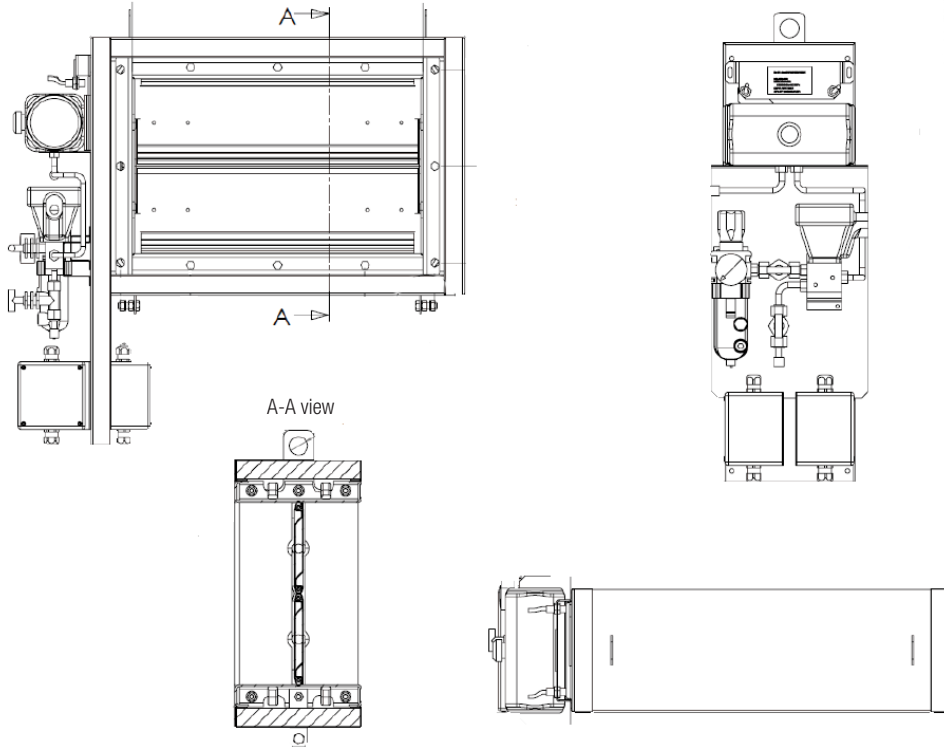

This product does not have preferential airflow direction

DESIGN (equipped with electric actuator)

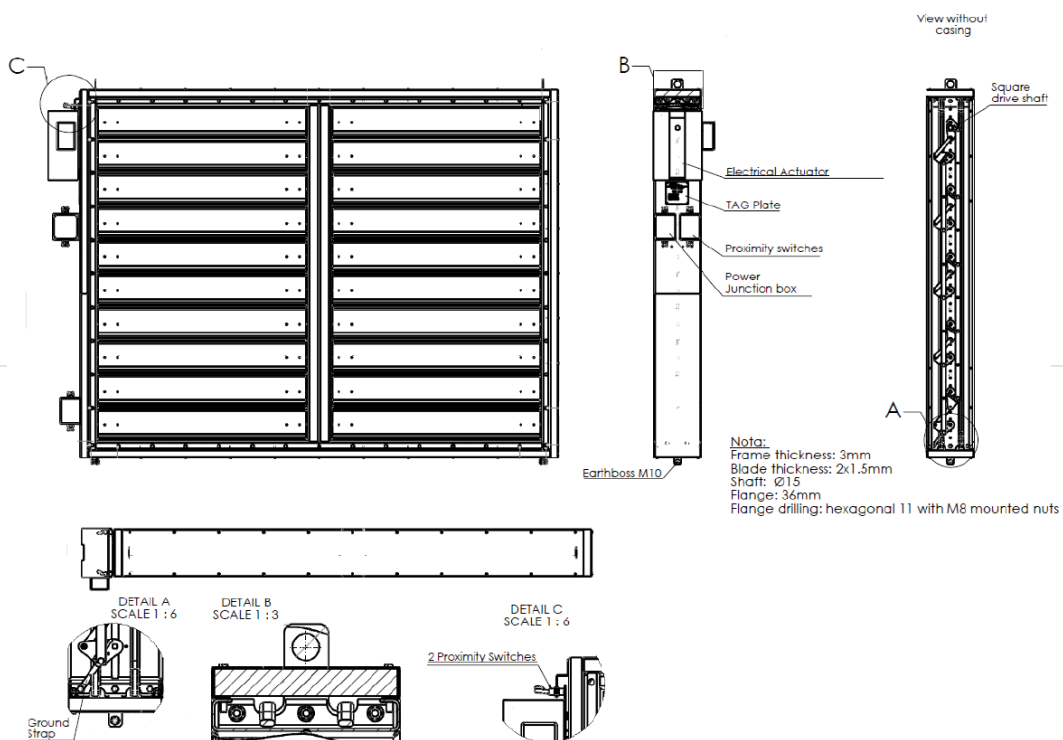

Information and data can not be considered as contractual. Design and data changes may occur without notice during F2A's continuous product development.



SHUT-OFF DAMPER

RKE-ATEX

MATERIALS

	RKE-ATEX	Options
Frame	Galvanized steel	Stainless steel AISI 316L
Blades	Galvanized steel	Stainless steel AISI 316L
Bearings	Self lubricated sintered bronze bearings, lubricated with Amide 10 DS wax	Teflon
Shafts	Galvanized steel	Stainless steel AISI 316L
Linkage	Galvanized steel	Stainless steel AISI 316L
Gaskets	Silicone gaskets on blades and frame	EPDM

CONSTRUCTION

		RKE-ATEX
Certification		 II 2 Gb c IIB/IIC T2...T6 IIIDb c IIIB/IIIC T60°C, T80°C, T120°C, T180°C, T220°C x  II 2 GD IIB - T3...T6 II 2 GD IIC - T3...T6 if blade's length <530 mm
Dimensions		Length from 400 to 2000 mm Height from 400 to 2000 mm with a pitch of 50 mm Circular adaptation from Ø100 to Ø1250mm
Leakage rate		Class 3 according to EN 1751 (leakage < 0.042m³/(m².s) under 2 000 Pa)
Frame	Thickness	3 mm
	Width	210 mm
	Drillings	According to ISO 15138 standard
	Flanges width	According to ISO 15138 standard
Linkage protection		Housing of the linkage
Blades	Thickness	2 x 1,5 mm
	Movement	Opposed type
	Shafts	Ø15 mm
Control		With pneumatic actuator and solenoid valve With electric actuator Manual control
Heat tracing of the frame		Possible on request

Information and data can not be considered as contractual. Design and data changes may occur without notice during F2A's continuous product development.

SHUT-OFF DAMPER

RKE-ATEX

2.1.12.B

CALCULATION CONDITIONS

The aeraulic features that are presented hereunder are valid when the products are used with a clean air in the following conditions:

- Temperature 20°C
- Hygrometry 50% HR
- Air pressure 101 325 Pa

Air velocities are given in meter per second m/s
 Pressures are given in Pascal Pa
 Temperatures are given in Degree Celsius °C
 All measurements are given in millimeter mm

AERAULIC FEATURES

RKE-ATEX	
Maximum operating pressure	1500 Pa for a 1500mm blade length
Operating temperature	From -50°C* to +180°C
Maximum air velocity	20 m/s

*as long as freezing does not occur on any part of the damper.

OPTIONS AND ACCESSORIES

- Junction box in stainless steel AISI 316L
- Inductive proximity switches
- Heat tracing of frame and/or blades

PERFORMANCES

Use limits

It is the difference between the upstream and downstream pressure that RKE-ATEX dampers can withstand.

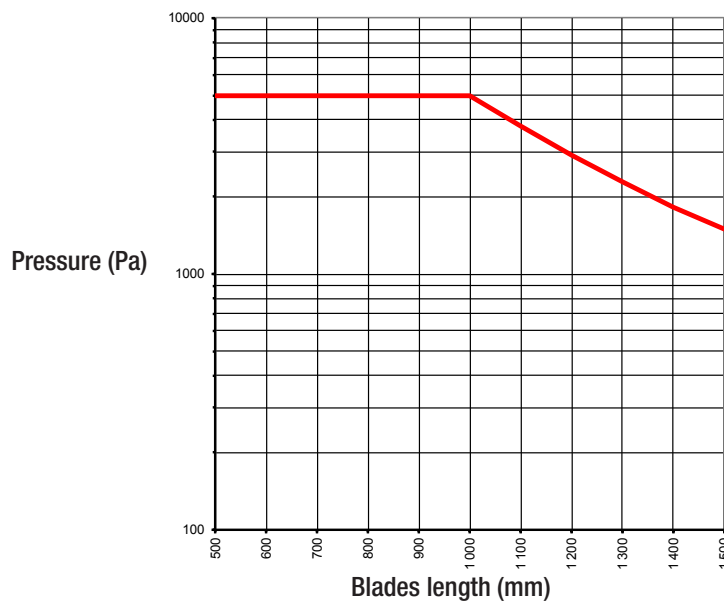

In order to improve pressure resistance, a vertical reinforcement can be used.

SHUT-OFF DAMPER

RKE-ATEX

REGENERATED NOISE

The acoustic performances of our dampers have been tested in an independent laboratory (CTTM) according to ISO 7235:2009 standard.

Air flow noise L_w in dB (blades opening angle 30°)



- Damper type RKE ATEX (opposed blade operation):

Air velocity (m/s)	Frequency (Hz)								
	63	125	250	500	1000	2000	4000	8000	Overall
2	34.3	34.8	31.7	27.5	26.3	27.3	34.3	38.8	42.8
4	43.4	48.7	47.2	45.5	43.8	40.5	36.8	39.0	53.6
6	51.3	56.6	57.7	55.8	54.6	52.8	49.3	42.2	63.3
8	59.4	63.0	65.5	65.5	61.8	60.5	58.1	50.6	71.3
10	66.0	67.9	68.6	74.3	67.9	66.4	64.4	57.7	77.6
12	71.8	72.6	71.4	79.6	73.2	71.3	69.3	63.2	82.6
15	77.3	79.0	76.0	86.2	80.5	77.2	75.1	69.7	89.0

Datas are given for a damper 450 x 500 mm.

From these data, you can calculate the regenerated noise of a damper of different dimensions by applying the formula below for every frequency band:

$$L_{w_{63}} = x_{63} + 10 \log \left(\frac{S}{0.225} \right)$$

x_{63} = Air flow noise for a damper 500 x 500 mm at 63 Hz (in dB) for a given air velocity => read the data in the table

S = Damper section (in m²).

$L_{w_{63}}$ = Air flow noise required at 63 Hz (in dB) for a given air velocity.

Example – Calculation of regenerated noise for a damper RKE ATEX 345 x 200 mm (HxL)

- Damper section : $S = 0.345 \times 0.2 = 0.069 \text{ m}^2$

Calculation of the regenerated noise at 63Hz for an air velocity of 4 m/s:

$$L_{w_{63}} = 43.4 + 10 \log \left(\frac{0.069}{0.225} \right) = 38.3 \text{ dB}$$

Value in the table at a frequency of 63Hz and for an air velocity of 4 m/s.

Repeat this calculation rules to get the regenerated noise for all frequencies (63Hz - 8kHz).

SHUT-OFF DAMPER

RKE-ATEX

2.1.12.B

VOLUME CONTROL

TESTS

The following tests are systematically carried out on 100% of our RKE-ATEX products :

- Measurements
- Appearance
- Manageability

Besides, airtightness, blade deflection and pressure resistance tests can be carried out on request.

PROVIDED DOCUMENTS

Materials certificates type 3.1 (for stainless steel material) or type 2.1 (for galvanized steel) according to EN 10204 standard for :

- Metal sheets of the blades
- Metal sheets of the frames

SAFETY AND PRESERVATION RULES

Refer to following documents :

- Operation manual for dampers CO-NOT-15-003 Ind 0
- Instruction manuals of accessories

Information and data can not be considered as contractual. Design and data changes may occur without notice during F2A's continuous product development.