

Suspension of the ventilation and / or airconditioning networks.

Possible assembly on telescopic leg - technical data sheet 7.2.1a.

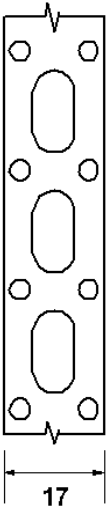
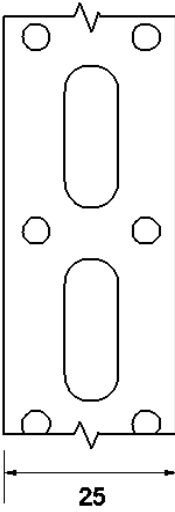

CONSTRUCTION

Width		17 mm	25 mm
Plan			
Material		Galvanized steel	
Ø of holes	Central	6 x 12 mm	8 x 21 mm
	On the side	3 mm	4 mm
Thickness		0.6 mm	0.8 mm
Advised load (Kg)		100	220
Breaking load (Kg)		200	440

Information and data can not be considered as contractual. Design and data changes may occur without notice during F2As continuous product development.