

SONIE BS

Standard acoustic splitter SONIE BS

- An aerodynamic frame including groove stiffening deformation
- A 50 kg/m³ sound insulation
- A protection with anti-erosion glass silk layer
- Assembly with rivets
- Acoustic performances tested in laboratory according to EN 7235 standard

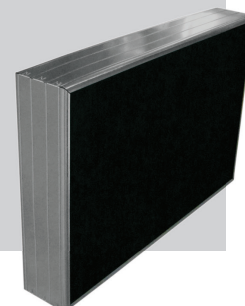

SONIE BS splitters include rounded edges, reducing pressure losses by 30% compared with ordinary splitters

SONIE BS splitters are designed to be installed in ventilation and air-conditioning systems within the limits mentioned in our technical datasheet.

Standard version can be supplied in 50, 100, 150, 200 or 300 mm thickness.

CONSTRUCTION

		Characteristics	Options
Frame	Material	Galvanised steel sheet with groove stiffening deformation	Stainless steel, painted or aluminium
	Thickness	0,6 mm	0,8 mm, 1 mm, 1,2 mm, 1.5 mm
	Width	50, 100, 150, 200 ou 300 mm	
	Assembly	Clips or rivets	Stainless or zinc-plated steel rivets
	Stiffener	Above 1800 mm length	
Sound proofing material	Material	Mineral wool panel Fire resistance A1	
	Density	50 kg/m ³	Other on request
	Protection	Anti-erosion glass silk	

Sound-proofing material can be provided with other protections such as: perforated steel sheets, stretched metal, fiberglass fabric, polyane or Tedlar housing. All these options are used in order to comply with most of the specifications according to applications.

For a complete silencer (splitter + casing), please refer to R-BL, R-BD, R-BP technical datasheet.

ACOUSTIC SPLITTERS

SONIE BS

DIMENSIONS

The splitters are made in one or several units depending on the dimensions.
A one unit construction shall respect the following criteria:

Length max. (mm)	2 500
Height max. (mm)	2 500
Surface max.	4 m ²
Weight max.	50 kg

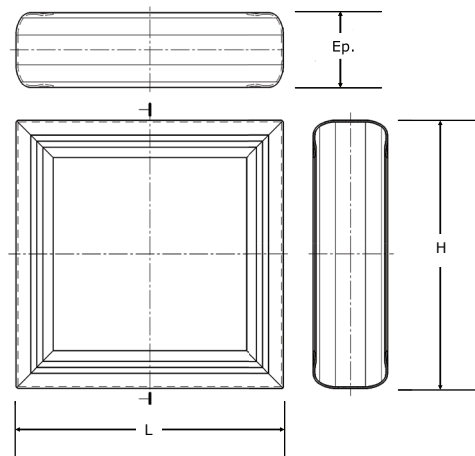

For larger dimensions, acoustic splitters are provided in several units with mounting accessories.

MOUNTING ACCESSORIES

Example for a 4 unit splitter:

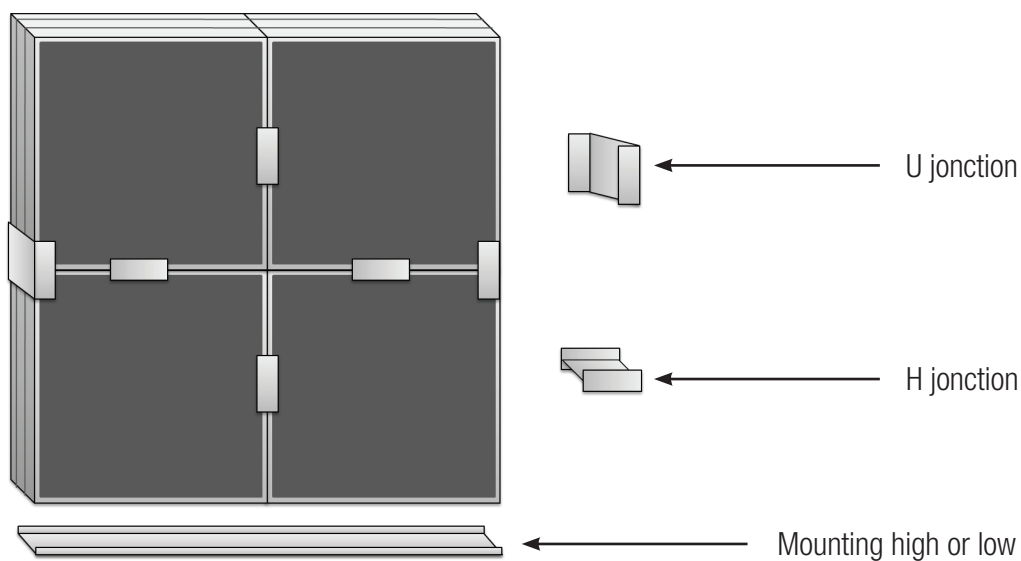

WEIGHTS (KG)

Thickness (mm)	Length		300	600	900	1200	1500	1800	2100	2400
	Height									
50	300		0.8	1.3	1.8	2.3	2.8	3.3	3.8	4.3
100			1.3	2.2	3.1	3.9	4.8	5.7	6.5	7.4
200			2.4	4	5.6	7.2	8.8	10.4	12	13.6
300			3.5	5.8	8.2	10.5	12.8	15.2	17.5	19.9
50	600		1.3	2	2.7	3.5	4.2	4.9	5.6	6.3
100			2.2	3.5	4.8	6.1	7.5	8.8	10.1	11.4
200			4	6.5	9	11.5	14	16.5	19	21.5
300			5.8	9.5	13.2	16.9	20.6	24.3	28	31.6
50	900		1.8	2.7	3.7	4.6	5.6	6.5	7.4	8.4
100			3.1	4.8	6.6	8.4	10.1	11.9	13.6	15.4
200			5.6	9	12.4	15.8	19.2	22.6	26	29.4
300			8.2	13.2	18.2	23.3	28.3	33.4	38.4	43.4
50	1200		2.3	3.5	4.6	5.8	7	8.1	9.3	10.5
100			3.9	6.1	8.4	10.6	12.8	15	17.2	19.4
200			7.2	11.5	15.8	20.1	24.4	28.7	33	37.3
300			10.5	16.9	23.3	29.7	36.1	42.4	48.8	55.2
50	1500		2.8	4.2	5.6	7	8.3	9.7	11.1	12.5
100			4.8	7.5	10.1	12.8	15.4	18.1	20.8	23.4
200			8.8	14	19.2	24.4	29.6	34.8	40	45.2
300			12.8	20.6	28.3	36.1	43.8	51.5	59.3	67
50	1800		3.3	4.9	6.5	8.1	9.7	11.4	13	14.6
100			5.7	8.8	11.9	15	18.1	21.2	24.3	27.4
200			10.4	16.5	22.6	28.7	34.8	40.9	47	53.1
300			15.2	24.3	33.4	42.4	51.5	60.6	69.7	78.8

RECOMMENDATIONS

The acoustic performances of a splitter silencer depend on the following parameters:

- **Air velocity**

The dynamic sound regeneration of a splitter is proportional to the air velocity in the airways. Dynamic regeneration sound level must not be higher than 10 dBA of the residual global sound level. See page 1.1.1A.6

- **Width**

For a same air velocity in an airway, a wider splitter is more efficient at low frequencies.

- **Length**

To improve acoustic performances, we recommend to mount two splitters sections in series (with a discharge plenum) rather than using very long splitters section. Attenuation of the two splitters can be added while the insertion losses of a long section reach their limits over 2500mm length.

- **Spacing between the splitters**

Air velocity depends on space between splitters. If the reduction of the spacing between the splitters improves the attenuation of the silencer, make sure that the dynamic sound regeneration will not reduce the global sound attenuation. In some cases, it is possible to mount two silencers in series with different splitters spacing to improve insertion loss at different frequency bands.

INSERTION LOSSES (dB)

Thickness 100 mm

Length of splitter	Airway spacing (mm)	Frequency (Hz)							
		63	125	250	500	1000	2000	4000	8000
600	50	1	3	8	15	29	30	19	12
	100	1	3	7	12	27	29	18	10
900	50	2	5	14	23	35	37	30	21
	100	2	3	10	18	34	38	25	13
1200	50	3	7	19	29	48	50	35	29
	100	2	4	12	24	47	49	30	19
1500	50	3	8	22	32	50	50	39	31
	100	2	6	15	30	50	50	36	24
1800	50	4	9	26	36	50	50	44	33
	100	3	8	20	33	50	50	39	27
2100	50	5	11	28	37	50	50	49	35
	100	3	9	22	36	50	50	43	29
2400	50	6	12	30	39	50	50	50	36
	100	4	10	23	41	50	50	44	32

Thickness 200 mm

Length of splitter	Airway spacing (mm)	Frequency (Hz)							
		63	125	250	500	1000	2000	4000	8000
600	100	2	4	10	20	26	26	16	11
	150	2	4	9	15	23	22	13	7
	200	1	3	6	14	18	17	10	5
	250	2	2	6	8	11	11	8	7
900	100	3	6	14	19	31	30	19	13
	150	2	5	13	22	30	29	16	11
	200	1	4	10	19	24	22	14	7
	250	2	3	9	11	16	14	10	9
1200	100	4	9	18	32	46	47	28	18
	150	3	7	17	29	39	38	19	12
	200	2	5	13	26	31	27	16	8
	250	3	4	11	15	21	18	11	11
1500	100	5	10	20	39	51	50	32	20
	150	4	9	20	36	47	45	22	14
	200	2	6	16	31	37	31	18	9
	250	3	4	13	18	26	21	12	12
1800	100	7	13	24	44	52	50	34	22
	150	5	11	24	43	52	52	25	15
	200	3	8	20	37	44	36	20	12
	250	4	5	15	21	30	25	14	13
2100	100	8	15	29	47	54	52	37	26
	150	6	13	27	47	53	53	27	17
	200	4	10	25	42	49	40	22	14
	250	4	6	17	24	35	27	15	14
2400	100	8	17	33	50	56	53	38	26
	150	6	14	27	49	55	54	29	18
	200	4	10	27	47	50	45	24	14
	250	4	8	19	28	39	30	17	15

Information and data can not be considered as contractual. Design and data changes may occur without notice during F2A's continuous product development.

DYNAMIC REGENERATION OF BS SPLITTERS

The dynamic regeneration must be 10 dB under the residual sound power level. If this is not the case, you have to increase the spacing between the splitters or the section of the duct.

Internal air velocity (m/s)	Frequency (Hz)							
	63	125	250	500	1000	2000	4000	8000
2	10	5	1	0	0	0	0	0
3	19	14	11	10	9	9	7	6
4	29	23	21	19	18	17	14	11
5	34	28	26	24	23	22	19	15
6	40	33	32	31	29	27	24	19
7	44	38	37	35	34	32	29	24
8	48	43	41	39	38	37	33	28
9	50	45	42	41	40	39	35	30
10	52	46	45	43	42	41	37	31
11	55	49	48	47	45	45	39	33
12	57	52	50	49	47	47	41	35
13	61	56	54	53	51	51	45	38
14	64	59	58	57	54	55	48	41
15	73	68	67	68	64	66	56	46

The data applies to an front section $L \times H = 0,8 \text{ m}^2$.

A correcting coefficient must be applied for different sections (see table below):

L x H (m ²)	0.1	0.2	0.4	0.8	1	2	4	8	10
Correction (dB)	-9	-6	-3	0	+1	+4	+7	+10	+11

Information and data can not be considered as contractual. Design and data changes may occur without notice during F2A's continuous product development.

ACOUSTIC SPLITTER

SONIE BS

BS SPLITTER'S PRESSURE DROP

The hereunder graph shows the pressure losses of a silencer equipped with SONIE BS splitters.

Thickness of each splitter: 200 mm

Airways spacing: 100 mm

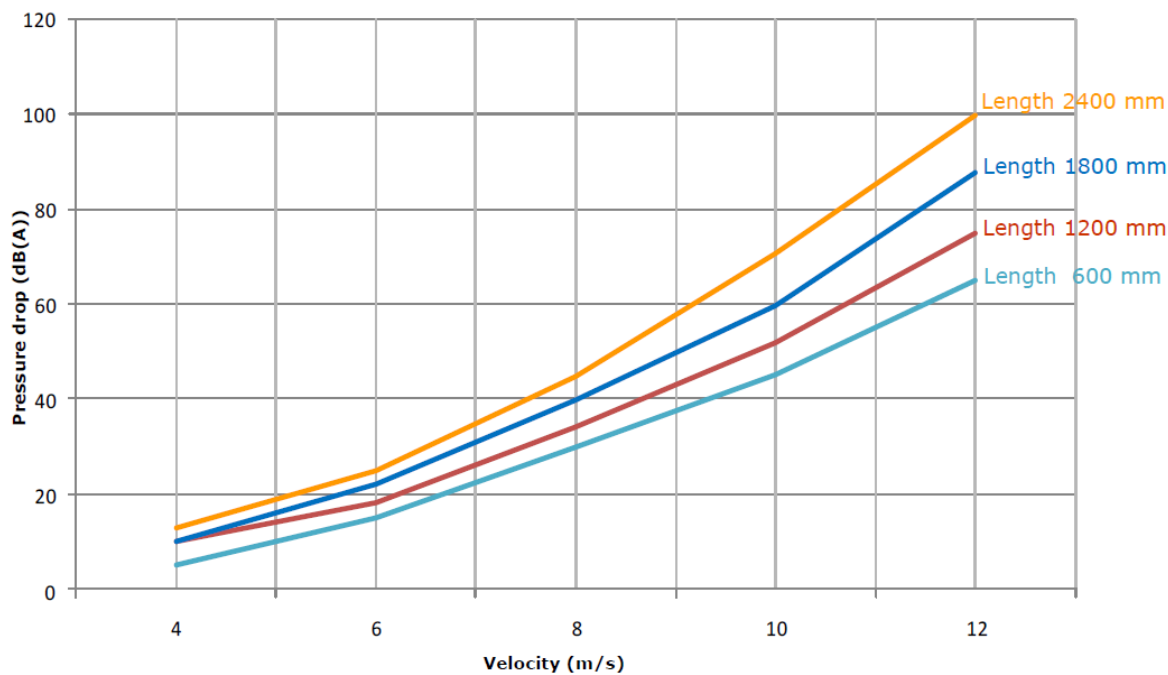

SPECIFICATIONS

- Aerodynamic rounded angle frame with groove stiffening deformation.
- Sound proofing panel of 50 kg/m³ density, inorganic, rot-proof and water repellent.
- Protected by an anti-erosion glass silk on both sides for an air velocity in the airways up to 14 m/s.